

# Structure of microfiche

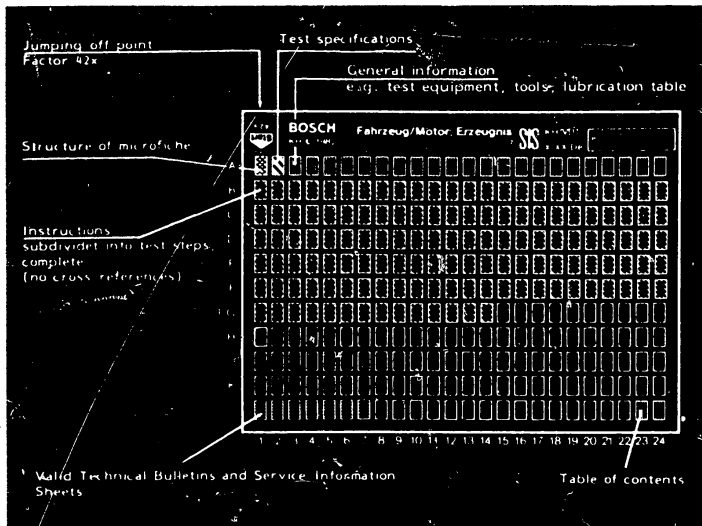

1. Read from left to right

2. Title of microfiche (appears on each coordinate)

<b>E 16</b>	Product/assembly/test step	
	Vehicle/engine	

Coordinate

3. Limits of section

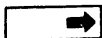

Beginning



Mid-section



End



One-page section

4. References to relevant test steps in test specifications; coordinate e.g. C6

**C6**

**A1**

Repair and testing



## 1. Test specifications

For test specifications see index of test-specification sheets VDT-W-231/1000 including test-specification sheets VDT-WPE 120/2 ... 21 and VDT-W-231/1001 etc.

Breaker-triggered ignition distributors 0 231 ... with retrofitted Hall generator are tested according to SIS test instructions W-231/301.

**A2**

Test specifications

Ignition distributors 0 231 ...



## 2. Necessary test equipment, tools

Distributor test bench ZVS 50	0 683 400 200
Tachometer e.g. KTE 001.03	0 684 400 103
Voltage stabilizer e.g. Gossen 12 V/10 A or battery 12 V 84 Ah e.g.	Commercially available
Contact feeler gauge or feeler gauge (0.05 ... 1 mm)	KDZV 7399 Commercially available
Ohmmeter e.g. ETE 014.00	0 684 101 400

**A3**

Test equipment, tools

Ignition distributors 0 231 ...



### 3. Lubricants

	Part No.
Plain-bearing grease	
VS 14060 Ft 250g can	5 964 520 125
High-temperature grease	
Ft 1V 4 50 g tube	5 700 002 005
Rolling-bearing grease	
Ft 1V 26 50 g tube	5 700 005 005
Silicon paste	
Ft 2V 4 50 g tube	5 700 083 005
Special oil	
01 1V 13 0.5 l can	5 962 260 605

#### 3.1 Lubrication table

##### General

The following exploded views show the points which must be treated with the stated lubricants.

Pay particular attention to footnotes.

The exploded views cannot be used for the assembly of ignition distributors (incomplete).

Contacts, including injection-triggering contacts, must be kept absolutely free from oil and grease (operational malfunctions).

**A4**

Lubricants, lubrication table

Ignition distributors 0 231 ...



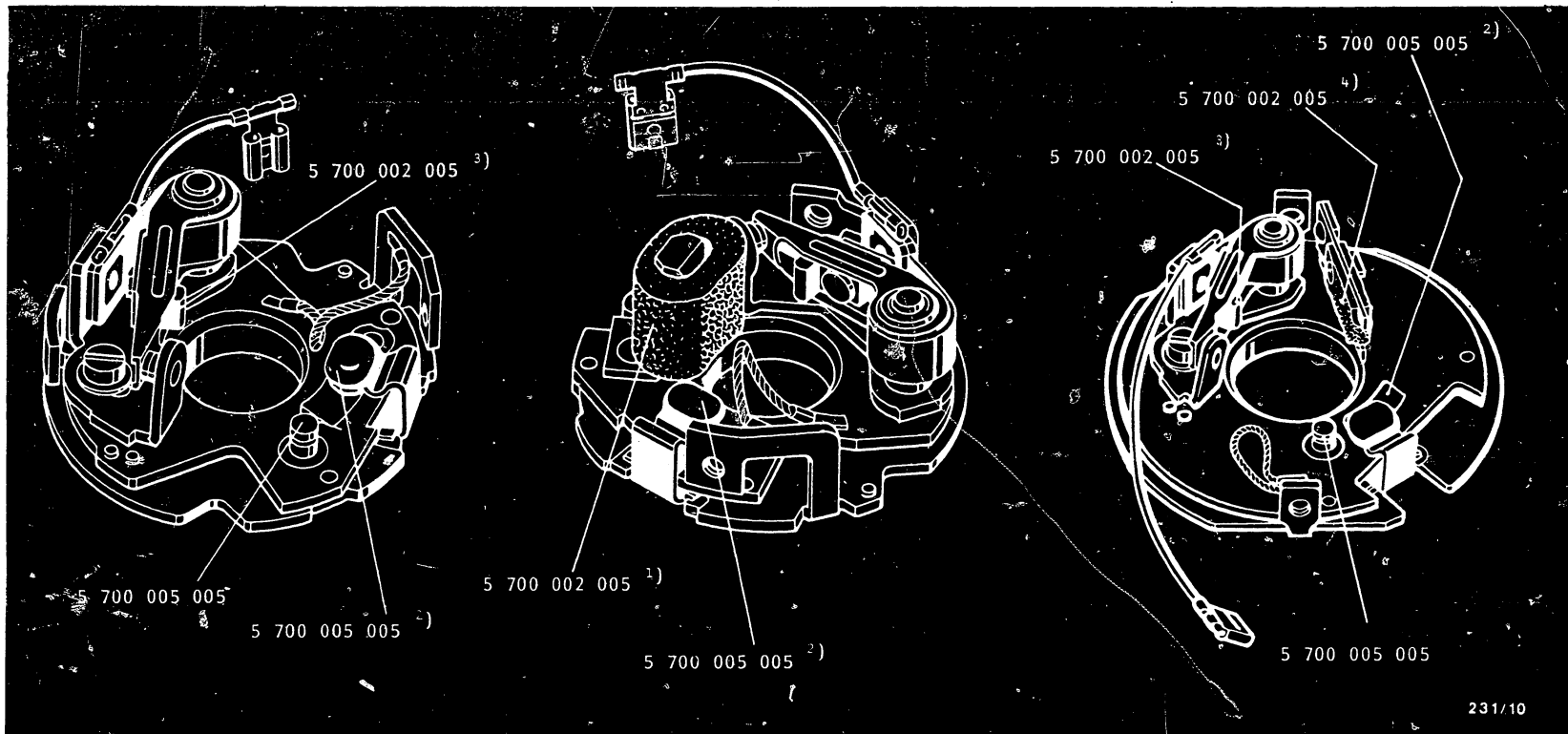

Lubrication points and lubricants on  
breaker-plate assembly  
Normal version

- 1) Rub grease into lubricating sponge
- 2) Running ball and sliding surfaces
- 3) Grease wedge on side of rivet head
- 4) Rub grease into lubricating felt

Breaker-plate assembly  
with sponge

Breaker-plate assembly  
with felt

**A5**

Lubrication table

Ignition distributors 0 231 ...



**A6**

Lubrication table

Ignition distributors 0 231 ...



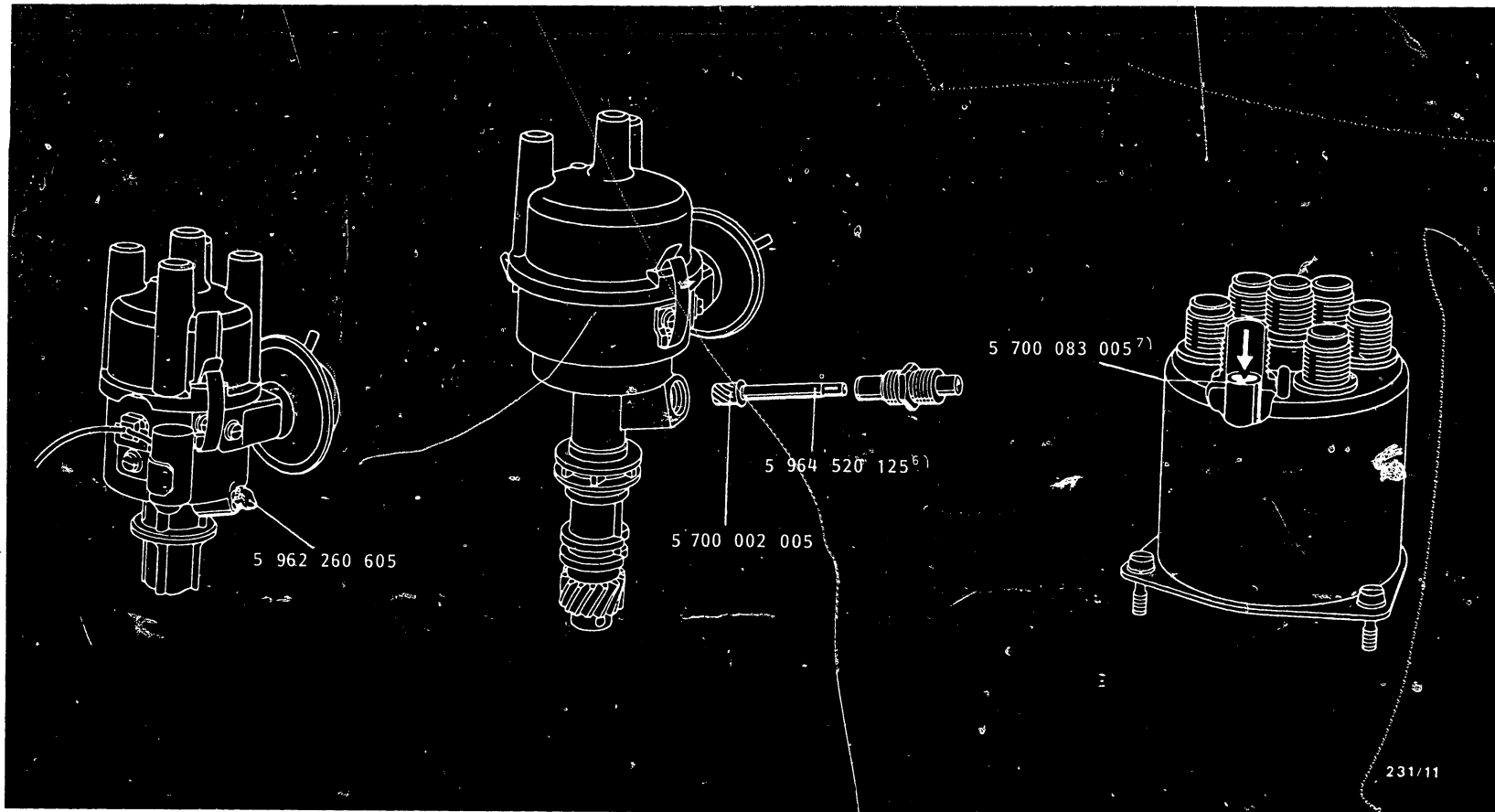

231/11

Lubrication points and lubricants on

Ignition distributor  
with oiler

Tachometer drive

6) Oil groove

Ignition distributor  
with interference-suppression  
cover

7) Each tower filled with  
approx. 60 mm<sup>3</sup>

**A7**

Lubrication table  
Ignition distributors 0 231 ...



**A8**

Lubrication table  
Ignition distributors 0 231 ...



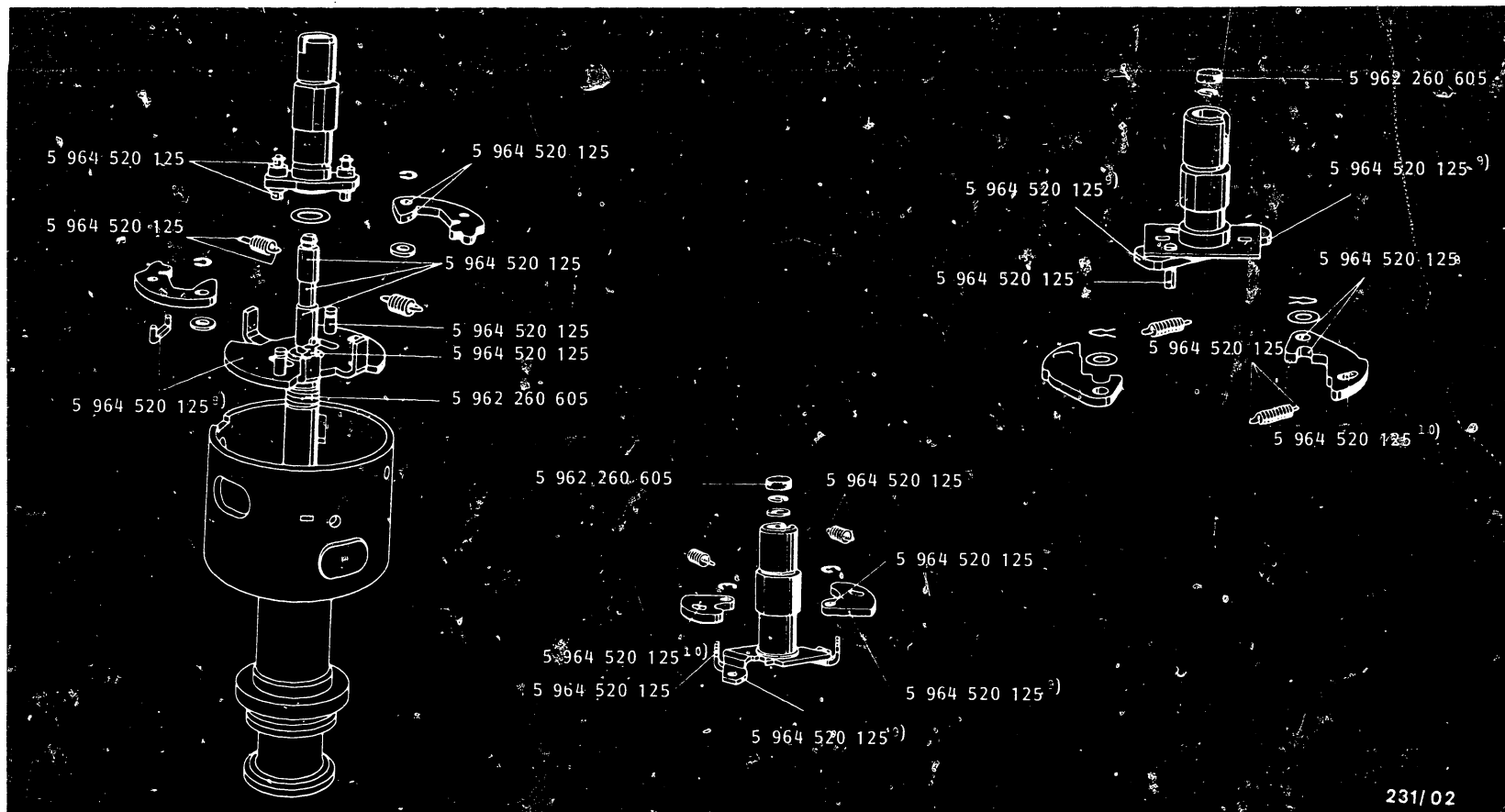

231/02

WG advance mechanism (with plastic rubbing block)

Rolling-contact advance mechanism

Sliding-contact advance mechanism

Lubrication points and lubricants on centrifugal advance mechanism

8) Grease plastic rubbing block and bearing surface on shaft plate

9) Grease sliding surface

10) Grease sliding nipple and its bearing surface on shaft plate

**A9**

Lubrication table

Ignition distributors 0 231 ...

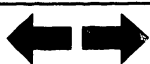

**A10**

Lubrication table

Ignition distributors 0 231 ...



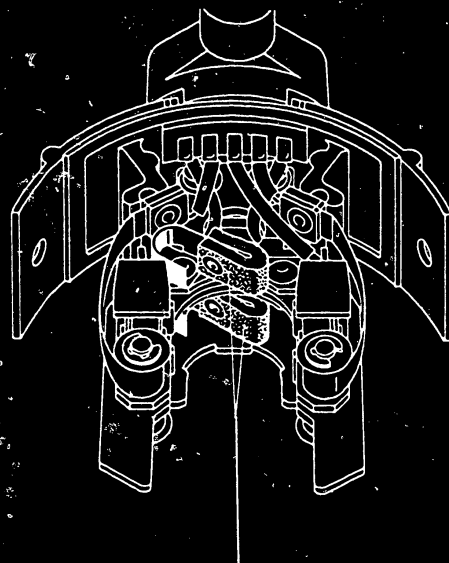

5 700 002 005<sup>4)</sup>

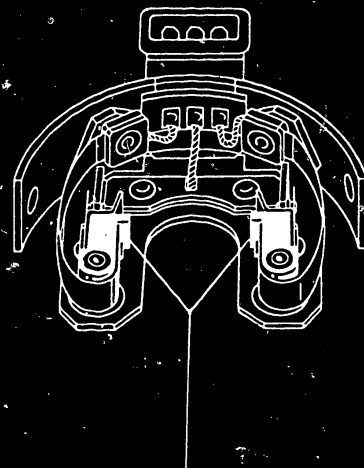

5 700 002 005<sup>5)</sup>

231/12

Lubrication points and lubricants on  
trigger contacts

- 4) Rub grease into lubricating felt
- 5) Grease wedge (sparingly) on side of  
rivet head

**A11**

Lubrication table  
Ignition distributors 0 231 ...



**A12**

Lubrication table  
Ignition distributors 0 231 ...





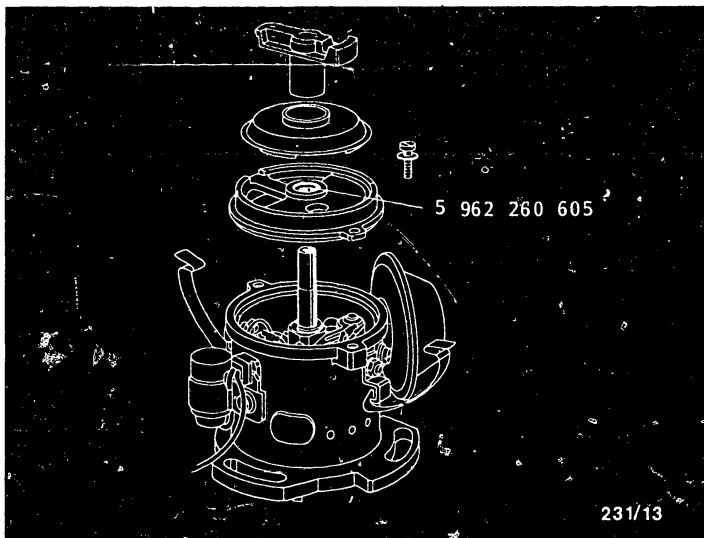

231/13

Lubrication points and lubricants on short-type  
ignition distributor

**A13**

Lubrication table  
Ignition distributors 0 231 ...



## 4. Testing

### 4.1 Test information

All rotational speeds given in the test specifications refer to the ignition distributor drive shaft.

The direction of distributor rotation (viewed looking down on the distributor cap) is given in the type designation,

e.g. IFU4 ← = clockwise rotation → = counterclockwise rotation  
or Z 42 ← = clockwise rotation → = counterclockwise rotation

The ignition distributor may only be driven with the distributor drive gear or coupling mounted in place (incorrect measurements can result from excessive longitudinal play in the distributor shaft).

The trigger contacts for electronic gasoline injection (only D-Jetronic) can only be examined visually.

In the case of ignition distributors without ignition condenser a condenser must be connected in parallel with the contact breaker for testing.



## 4.2 Visual examination

The contacts must not be loose. Twisted or misaligned contacts must be replaced.

Check the breaker lever rubbing block, contacts and cams for wear and damage,

The spring of the breaker lever must not be bent, burned out or rusted. The contact points and the trigger contacts for electronic gasoline injection (D-Jetronic) must be absolutely free from oil and grease.

Dirty contact points cause heavy contact arcing, reduce the ignition performance and considerably shorten the service life of the contacts. Oil-fouled and dirty trigger contacts for electronic gasoline injection cause malfunctions in pulse triggering.

The distributor cap and the distributor rotor must be clean and must have no cracks or leakage paths.



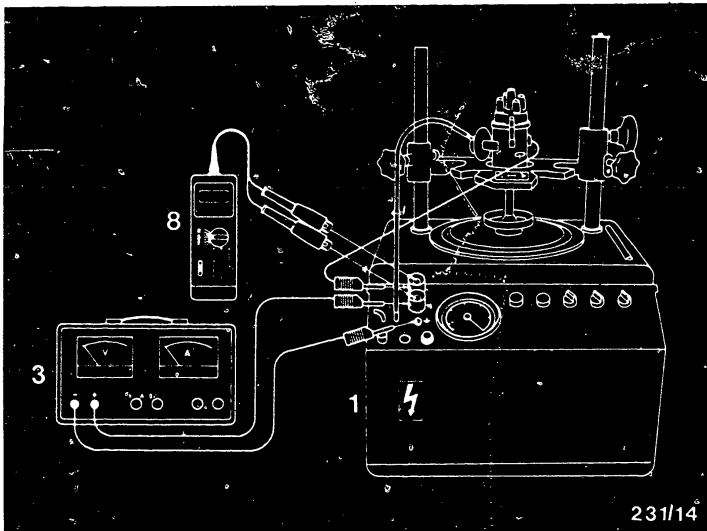

231/14

- 1 = Distributor test bench
- 3 = Voltage stabilizer/battery
- 8 = Tach-dwell meter

#### 4.3 Testing the dwell angle (Test specifications VDT-WPE 120/2 .. 21 or VDT-W-231/100i etc).

Mount the ignition distributor on the distributor test bench and connect to the test equipment as shown in the above diagram. Follow the operating instructions for the individual testers.

**B3**

Testing

Ignition distributors 0 231 ...



Switch on the 12 V power supply.

Operate the ignition distributor at a speed which is about  $100 \text{ min}^{-1}$  below the speed for the earliest start of centrifugal advance (see test specifications).

Read off the indicated dwell angle (average of all cylinders) and compare with test specifications.

Switch off power supply.

Note

Set the dwell angle to the middle of the tolerance range. Wear on contacts, rubbing block, cams and distributor-shaft mounting changes the dwell angle.

The dwell angle is dependent on the cam contour and the contact gap.



4.4 Testing the contact gap (Test specifications VDT-WPE 120/2 ... 21 or VDT-W-231/1001 etc).

The value given is the minimum value. After setting the dwell angle, check the contact gap with the contact feeler gauge. The largest contact gap is when the breaker lever rubbing block is on the highest point of the cam.

If the contact gap is not reached, there is a defective cam.

4.5 Testing the ignition condenser (not given in test specifications)

Test the series resistance with ignition tester following the respective operating instructions.

Note

The ignition condenser must be well grounded to the distributor housing; the insulated connecting lead must have proper contact with terminal 1 of the ignition distributor. In the event of a short circuit (no ignition sparks) or an open circuit in the condenser (poor ignition performance and heavy contact arcing) the ignition condenser must be replaced.



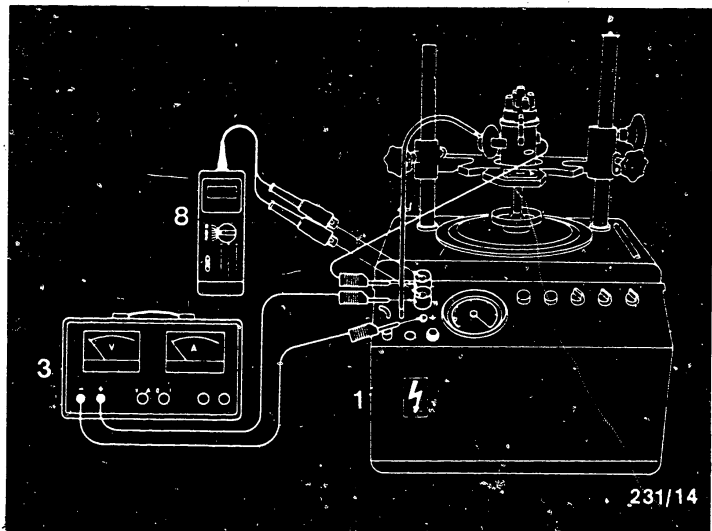

- 1 = Distributor test bench  
 3 = Voltage stabilizer/battery  
 8 = Tach-dwell meter

#### 4.6 Testing the centrifugal advance

Test specifications VDT-WPE 120/2 ... 21 or VDT-W-231/1001 etc)

Mount the ignition distributor in position, and connect it to the test equipment as shown in the above diagram. Follow the operating instructions for the individual testers.

**B6**

Testing  
 Ignition distributors 0 231 ...

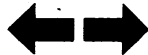

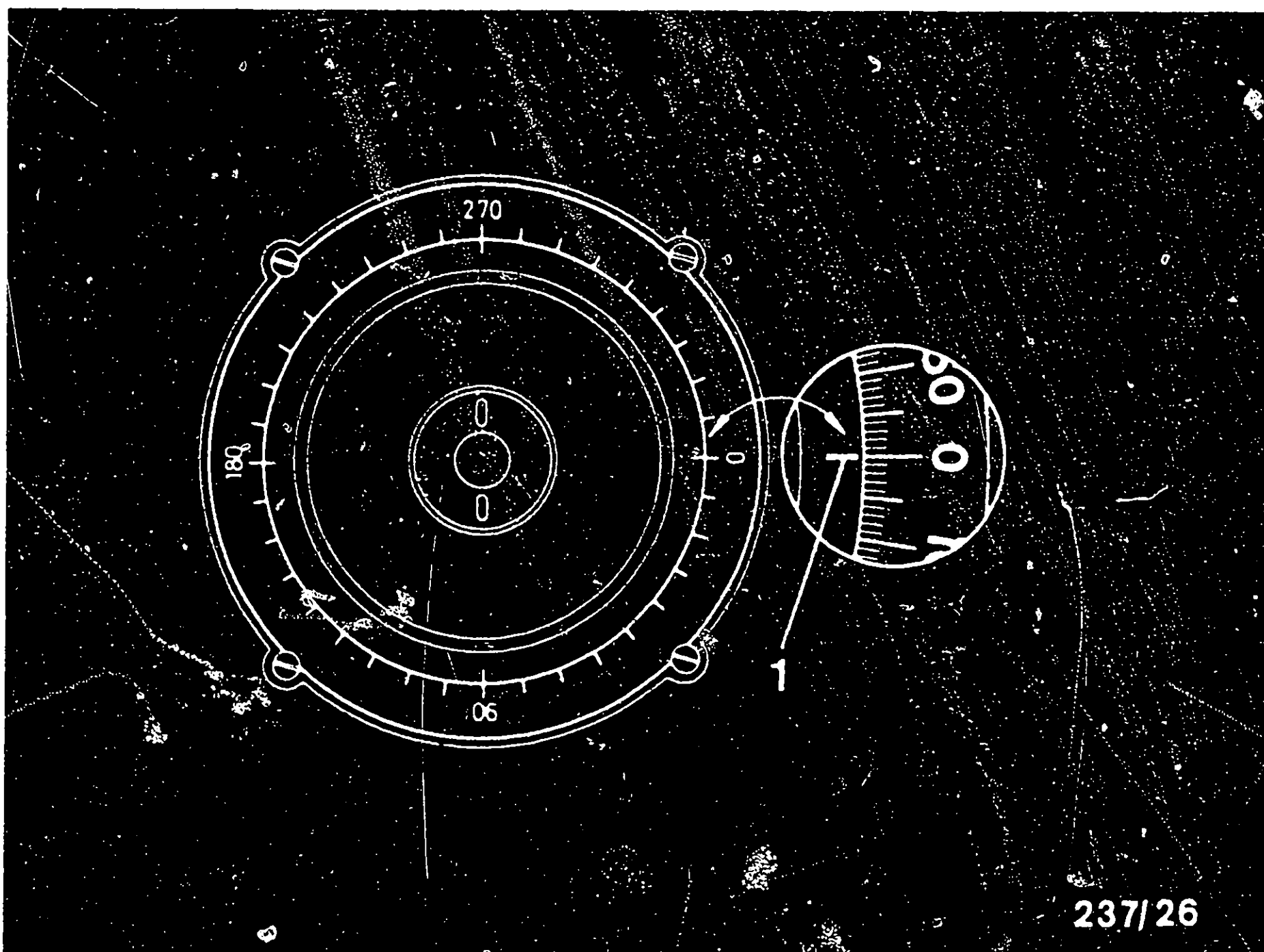

237/26

1 = Illuminated mark

Switch on the 12 V power supply.  
Operate the ignition distributor at a speed which is  $100 \text{ min}^{-1}$  below the speed for the earliest start of centrifugal advance (see test specifications).  
Then turn the scale ring of the distributor test bench or ignition distributor so that the illuminated mark of a cylinder lights up at  $0^\circ/360^\circ$  (zero point).  
See illustration. Tighten tightening screw of ignition distributor or clamping ring of chuck.

**B7**

Testing

Ignition distributors 0 231 ...





The centrifugal advance is checked at least twice at each change of direction as well as in the end range of a curve. The test is only to be carried out with increasing speed (this avoids measurement errors).

Read off the advance angle and compare with test specifications. See figures for examples. If an addition to the tolerance range of  $\pm 0.5^\circ$  is given in the test specifications, the upper line of the tolerance range must be extended by  $0.5^\circ$  to the top, and the lower line by  $0.5^\circ$  to the bottom.

If the specified values are not reached, the ignition distributor (advance system) is defective.

Switch off the power supply.

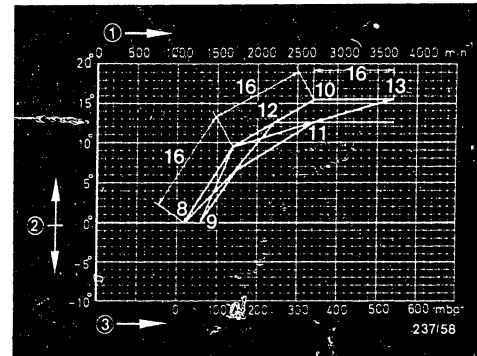

- 1 = Distributor shaft speed
- 2 = Distributor shaft advance
- 3 = Negative gauge pressure (Vacuum)
- 8/9 = Start of centrifugal advance
- 10/11 = End of centrifugal advance
- 12/13 = In extreme cases the end of centrifugal advance may be located here.
- 16 = Change in curve direction

**B8**

Testing  
Ignition distributors 0 231 ...

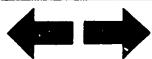

**B9**

Testing  
Ignition distributors 0 231 ...



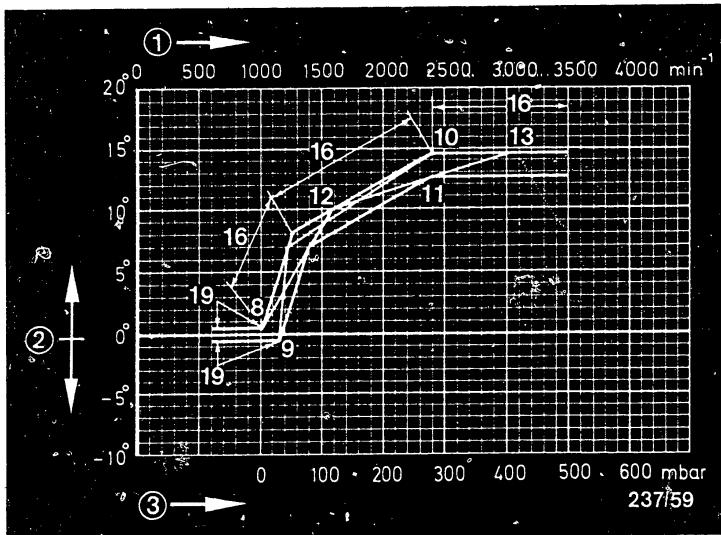

- 1 = Distributor shaft speed  
 2 = Distributor shaft advance  
 3 = Negative gauge pressure (vacuum)  
 8/9 = Start of centrifugal advance  
 10/11 = End of centrifugal advance  
 12/13 = In extreme cases the end of centrifugal advance  
           may be located here.  
 16 = Change in curve direction  
 19 = "Adjustment base"

Advance curve with "adjustment base" (19)

After the zero point adjustment of the distributor test bench (scale ring) it is possible, without the centrifugal advance operating, for there to be a slight advance (max. 0.5°) although the centrifugal advance only starts at points 8/9.



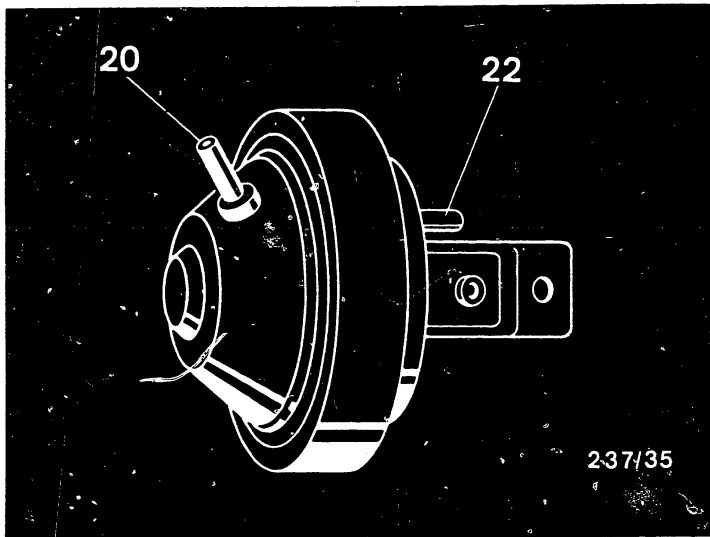

20 = Vacuum connection "retard"

22 = Gauge pressure connection "advance"

Note: According to DIN the term "vacuum" should be replaced with "negative gauge pressure". For the sake of simplicity, however, we will continue to use "vacuum".

#### 4.7 Testing the vacuum advance

##### 4.7.1 Testing the vacuum unit for leaks (not given in test specifications)

Connect the vacuum connection hose from the distributor test bench to the vacuum unit.

Increase the vacuum using the vacuum pump until 600 mbar is reached. Switch off the vacuum pump.



The maximum permissible pressure drop in 1 minute is 20%. Eliminate any leaks at the connection. Replace leaky vacuum advance mechanisms.

**B12**

Testing

Ignition distributors 0-231....



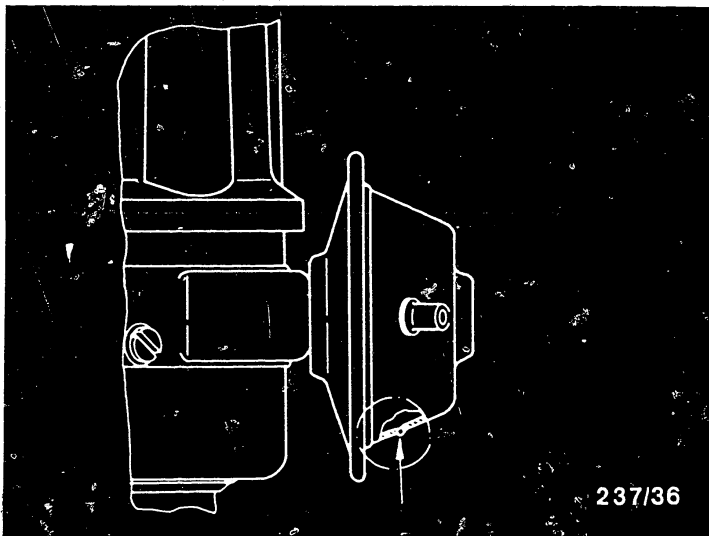

In the event of an extremely heavy pressure drop check whether the vacuum unit has a vent hole (approx. 0.5 mm diameter). See picture, arrow. The hole should be sealed while testing for leaks.

**B 13**

Testing  
Ignition distributors 0 231 ...



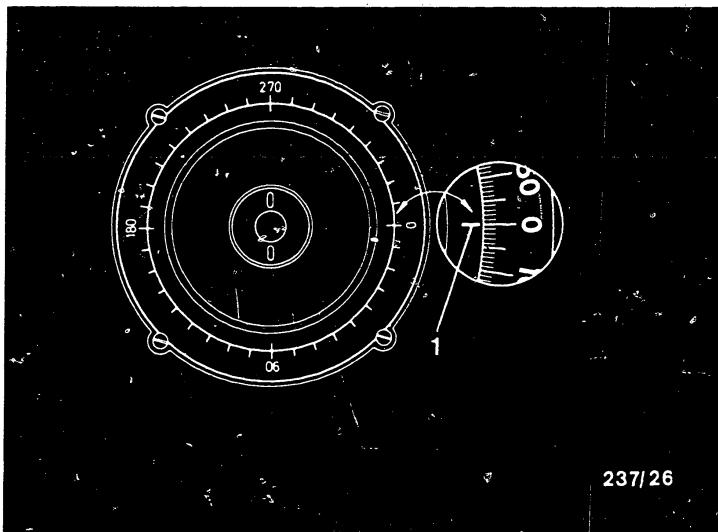

237/26

1 = Illuminated mark

4.7.2 Testing the vacuum advance (Test specifications VDT-WPE 120/2 ... 2.1 or VDT-W-231/1001 etc).

Mount the ignition distributor in position and connect to test equipment. Switch on the 12 V power supply.

Operate the ignition distributor at a speed which is  $200 \text{ min}^{-1}$  above the end of centrifugal advance (see test specifications).

Turn the scale ring of distributor test bench or turn the ignition distributor so that the illuminated mark of a cylinder lights up at  $0^\circ/360^\circ$ . See picture. Tighten tightening screw of ignition distributor or clamping ring of chuck.

**B14**

Testing

Ignition distributor 0 231 ...





If the values measured are not within the tolerance range, check the breaker-plate assembly and tie rod for freedom of movement.  
 When the end of vacuum advance has been reached, an increase in the vacuum must not result in an additional advance.

Switch off the power supply.

Advance curve with "adjustment base" (19)

After the zero point adjustment of the distributor test bench (scale ring) it is possible with increasing vacuum for there to be a slight advance (max. 0.5°) although the actual vacuum advance only starts at points 8/9 or 12/13.

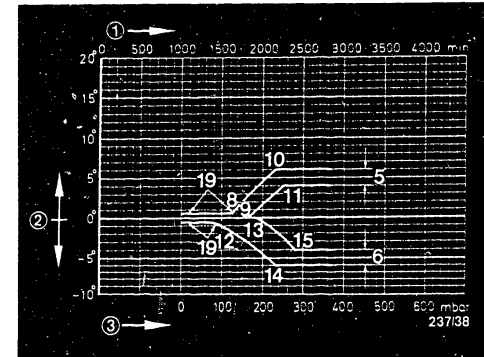

- 1 = Distributor shaft speed
- 2 = Distributor shaft advance
- 3 = Negative gauge pressure (vacuum)
- 5 = Negative gauge pressure (vacuum) advance
- 6 = Negative gauge pressure (vacuum) retard
- 8/9, 12/13 = Start of vacuum advance "Advance and retard unit"
- 10/11, 14/15 = End of vacuum advance "Advance and retard unit"
- 19 = "Adjustment base"

**B 16**

Testing

Ignition distributors 0 231 ...

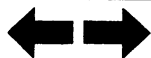

**B 17**

Testing

Ignition distributors 0 231 ...





4.8 Vacuum/overpressure advance - test pressure unit with one or two connecting pipes.  
(Test specifications VDT-WPE 120/2 ... 21 or VDT-W-231/1001 etc).

#### 4.8.1 Testing the vacuum unit or overpressure unit for leaks

(Not given in test specifications)

Connect vacuum hose of distributor test bench to pressure unit.

In the case of the vacuum/overpressure unit with double retard, the overpressure unit is also tested for leaks with vacuum.

In the case of the vacuum/overpressure unit with one connecting pipe, the advance and retard unit is tested for leaks with vacuum.

Increase the vacuum using the vacuum pump until 600 mbar is reached. Switch off the vacuum pump.

Permissible pressure drop in 1 minute max. 20%.

Eliminate any leaks at the connection. Replace vacuum advance mechanisms if leaking.

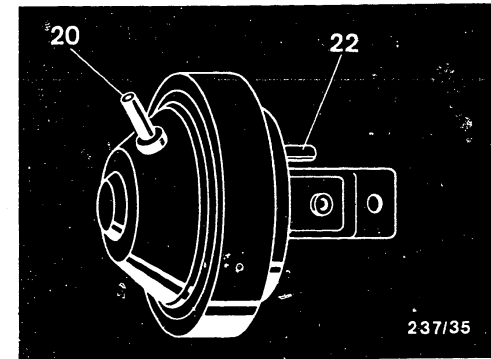

20 = Vacuum connection "retard"  
22 = Overpressure connection  
"retard"

23 = Vacuum connection "advance"  
and  
overpressure connection  
"retard"

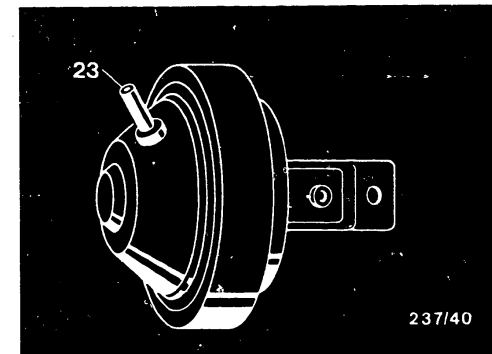

**B18**

Testing

Ignition distributors 0 231 ...



**B19**

Testing

Ignition distributors 0 231 ...



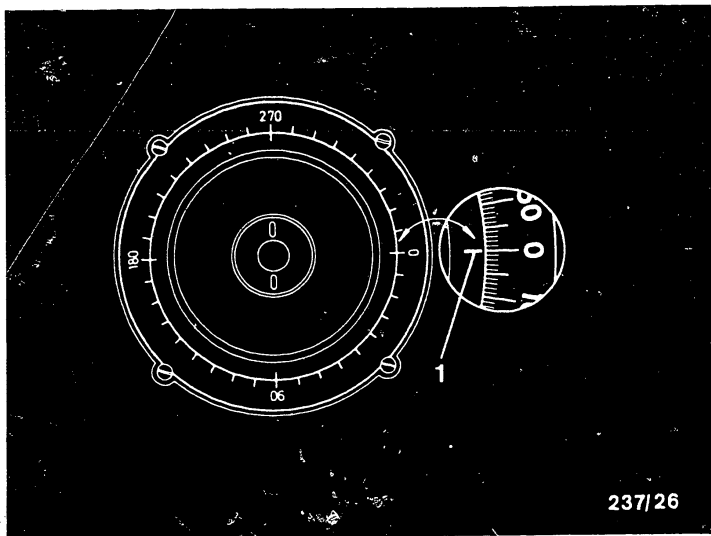

237/26

1 = Illuminated mark

#### 4.8.2 Testing the vacuum advance

Mount the ignition distributor in position and connect to test equipment. Switch on the 12-V power supply.

Operate the ignition distributor at a speed which is  $200 \text{ min}^{-1}$  above the end of centrifugal advance (see test specifications).

Turn the scale ring of distributor test bench or turn the ignition distributor so that the illuminated mark of a cylinder lights up at  $0^\circ/360^\circ$ . See picture. Tighten tightening screw of ignition distributor or clamping ring of chuck.

**B20**

Testing

Ignition distributors 0 231 ...



Check whether, with increasing vacuum, the advance angle is within the given tolerance range. See figures for example.

If an addition to the tolerance range of  $\pm 0.5^\circ$  is given in the test specifications, the upper line must be extended by  $0.5^\circ$  to the top, and the lower line by  $0.5^\circ$  to the bottom. If the measured values are not within the tolerance range, check the breaker-plate assembly and tie rod for freedom of movement.

After reaching the end of advance, an increase in the vacuum must not cause any further advance.

#### Advance curve with "adjustment base" (19)

After the zero point adjustment of the distributor test bench (scale ring) it is possible, with increasing vacuum, for there to be a slight advance (max.  $0.5^\circ$ ) although the actual vacuum advance only starts at points 8/9.

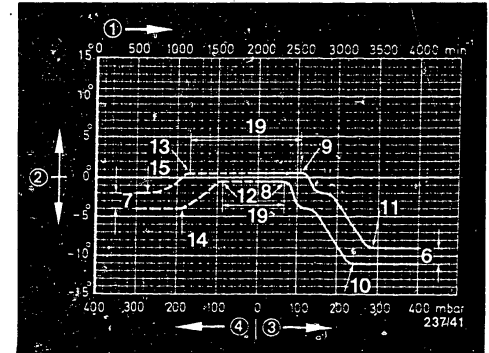

- 1 = Distributor shaft speed
- 2 = Distributor shaft advance
- 3 = Negative gauge pressure (vacuum)
- 4 = Overpressure
- 6 = Negative gauge pressure (vacuum) retard
- 7 = Overpressure retard
- 8/9, 12/13 = Start of vacuum/overpressure advance with double retard
- 10/11, 14/15 = End of vacuum/overpressure advance with double retard
- 19 = "Adjustment base"

**B21**

Testing  
Ignition distributor 0 231 ...



**B22**

Testing  
Ignition distributor 0 231 ...



Further example of an advance curve, e.g. vacuum advance

Advance curve with "adjustment base"

After the zero point adjustment of the distributor test bench (scale ring) it is possible, with increasing vacuum, for there to be a slight advance (max. 0.5°) although the actual vacuum advance only starts at points 12/13.

Note

A double unit with one connecting pipe "advances" when vacuum is applied and "retards" when overpressure is applied.

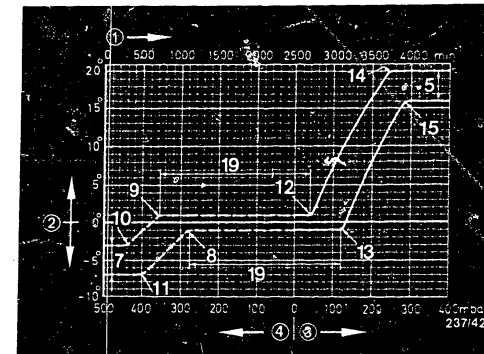

- 1 = Distributor shaft speed
- 2 = Distributor shaft advance
- 3 = Negative gauge pressure (vacuum)
- 4 = Overpressure
- 5 = Negative gauge pressure (vacuum) advance
- 7 = Overpressure retard
- 8/9, 12/13 = Start of vacuum/overpressure advance with advance/retard
- 10/11, 14/15 = End of vacuum/overpressure advance
- 19 = "Adjustment base"

**B23**

Testing

Ignition distributors 0 231 ...



**B24**

Testing

Ignition distributors 0 231 ...



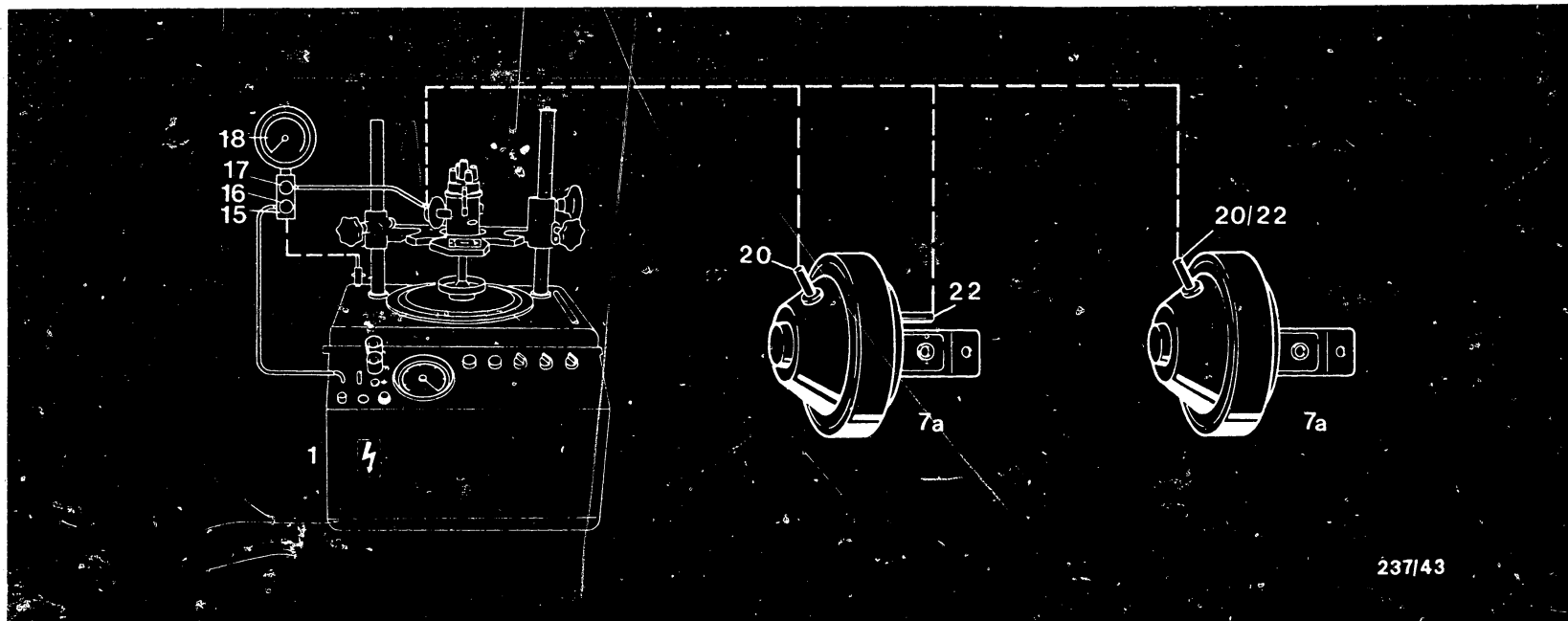

237/43

1 = Distributor test bench  
 7a = Vacuum/overpressure unit  
 15 = Adjustment throttle

16 = Adjusting screw  
 17 = Screw plug  
 18 = Pressure gauge

20 = Vacuum connection "retard"  
 22 = Overpressure connection "retard"

#### 4.8.3 Testing the overpressure advance

Mount the ignition distributor on the distributor test bench. Connect the overpressure connection of the distributor test bench to the lower connection of the adjustment throttle. Connect the overpressure connection of the ignition distributor to the upper connection of the adjustment throttle. See connection diagram above.

Note: Adjusting screw (16) is for adjusting the pressure. If a pressure of 1.2 bar is not reached, unscrew adjusting screw (16) and coat thread with viscous grease. Re-insert adjusting screw (16). Screw plug (17) is open during testing.

**C1**

Testing  
 Ignition distributors 0 231 ...



**C2**

Testing  
 Ignition distributors 0 231 ...



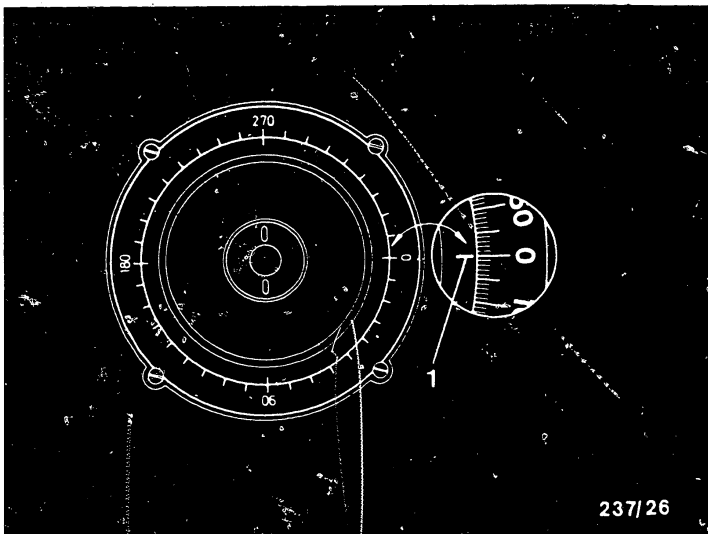

1 = Illuminated mark

Connect the ignition distributor to the test equipment.  
Switch on the 12V power supply.

Operate the ignition distributor at a speed which is 200 min<sup>-1</sup> above the end of centrifugal advance (see test specifications).

Turn the scale ring of distributor test bench or turn the ignition distributor so that the illuminated mark of a cylinder lights up at 0°/360°. See picture. Tighten tightening screw of ignition distributor or clamping ring of chuck.

**C3**

Testing

Ignition distributor 0 231



Check whether, with increasing overpressure, the advance angle is within the stated tolerance range. See figures for examples.

If an addition to the tolerance range of  $+ 0.5^\circ$  is given in the test specifications, the upper line must be extended by  $0.5^\circ$  to the top, and the lower line by  $0.5^\circ$  to the bottom. If the measured values are not within the tolerance range, check the breaker-plate assembly and tie rods for freedom of movement.

After reaching the end of advance, an increase in the overpressure must not cause any further advance.

#### Advance curve with "adjustment base" (19)

After the zero point adjustment of the distributor test bench (scale ring) it is possible, with increasing overpressure, for there to be a slight advance (max.  $0.5^\circ$ ) although the actual overpressure advance only starts at points 12/13.

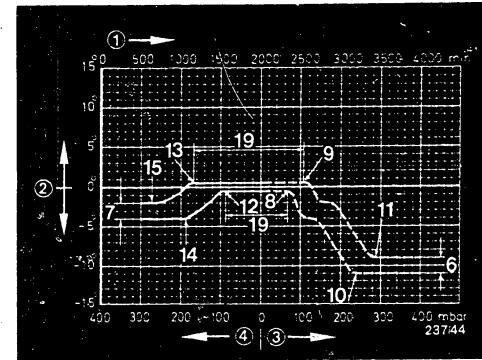

- 1 = Distributor shaft speed
- 2 = Distributor shaft advance
- 3 = Negative gauge pressure (vacuum)
- 4 = Overpressure
- 6 = Negative gauge pressure (vacuum) retard
- 7 = Overpressure retard
- 8/9, 12/13 = Start of vacuum/overpressure advance with double retard.
- 10/11, 14/15 = End of vacuum/overpressure advance with double retard
- 19 = "Adjustment base"

**C4**

Testing

Ignition distributor 0 231



**C5**

Testing

Ignition distributor 0 231



### Further example of an advance curve, e.g. overpressure retard

#### Advance curve with "adjustment base" (19)

After the zero point adjustment of the distributor test bench (scale ring) it is possible, with increasing overpressure, for there to be a slight advance (max.  $0.5^\circ$ ) although the actual overpressure advance only starts at points 8/9.

Note: A double unit with one connecting pipe "advances" when vacuum is applied and "retards" when overpressure is applied. Switch off the power supply.

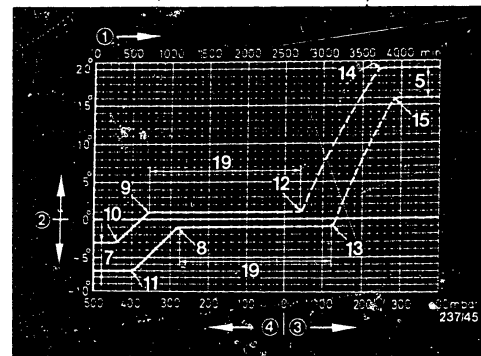

- 1 = Distributor shaft speed
- 2 = Distributor shaft advance
- 3 = Negative gauge pressure (vacuum)
- 4 = Overpressure
- 5 = Negative gauge pressure (vacuum) advance
- 7 = Overpressure retard
- 8/9, 12/13 = Start of vacuum/overpressure advance with advance/retard
- 10/11, 14/15 = End of vacuum/overpressure advance
- 19 = "Adjustment base"

**C6**

Testing

Ignition distributor 0 231



**C7**

Testing

Ignition distributor 0 231





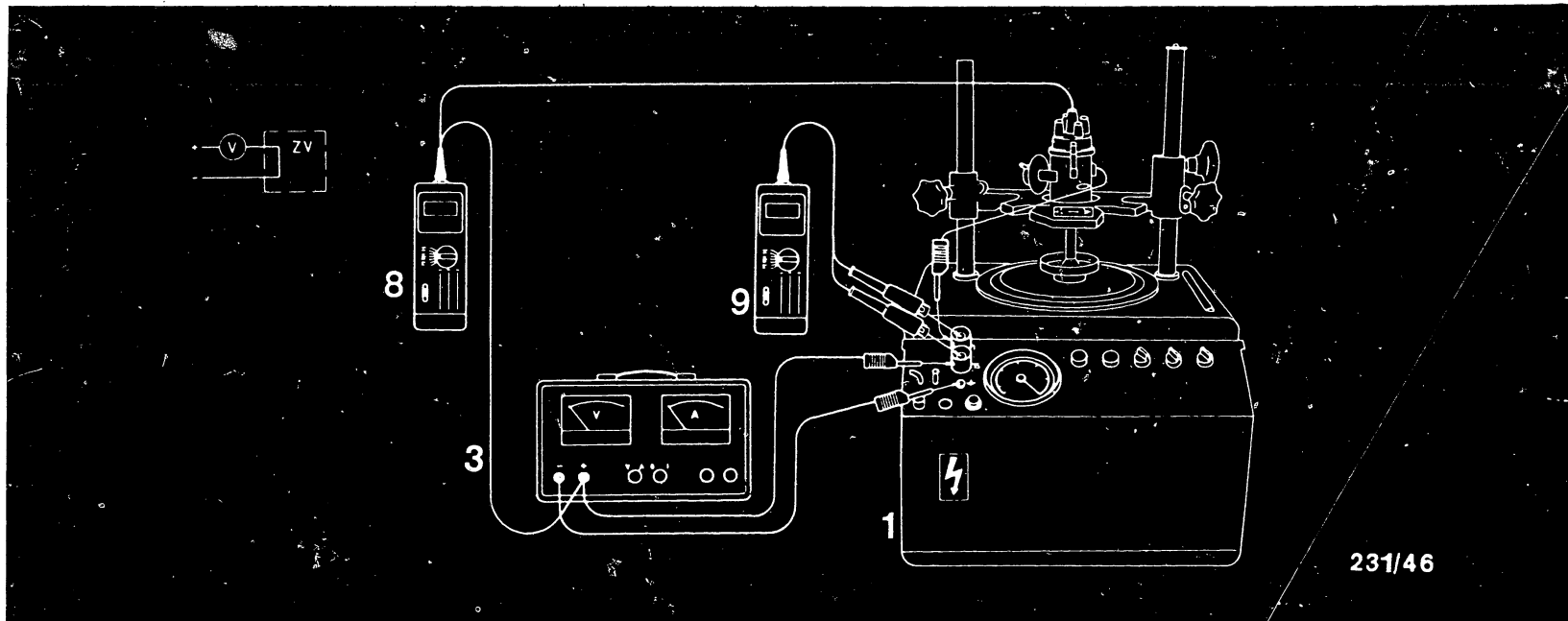

1 = Distributor test bench with  
ignition distributor

3 = Voltage stabilizer/battery

8 = Voltmeter  
9 = Tachometer

5. Testing the engine-speed limiter (test specifications VDT-WPE 120/2...21 or VDT-W-231/1001 etc.)

Mount the ignition distributor and connect to the test equipment as shown in the above diagram. Follow the operating instructions for the individual testers.

Switch on the 12 V power supply.

Operate the ignition distributor at the specified speed.

The engine-speed limiter is OK if, up to the specified minimum speed, the voltmeter indicates no voltage and, as of the specified maximum speed, it indicates voltage.

Switch off the power supply.

C8

Testing

Ignition distributor 0 231



C9

Testing

Ignition distributor 0 231



# After-sales Service

## Technical Bulletin

Only for use within the Bosch organization. Not to be communicated to any third party.

0 231..

Short-type ignition distributor

ZV  
VDT-BME 121/89 23

VDT-1-230/101

10.7.1974

Destroy edition of 28.5.1974

The position of the second shaft bearing (bearing end plate) above the distributor contact points makes it necessary to observe the following points under all circumstances when carrying out maintenance operations.

1. In order to remove and install the distributor contact points, remove the bearing end plate (avoid fouling the bushing). With the bearing end plate removed, the distributor must not be driven (engine, distributor test bench) since, otherwise, the lower bearing bushing in the distributor will be damaged. The contact gap and dwell angle must not be checked or adjusted without the bearing end plate (incorrect measurement).
2. Whenever changing the contact points, apply a drop of oil to the upper bearing bushing (see arrow)  
(OL 1 v13, oil can 0.05 liter - Part No. 5 701 042 350,  
can 0.5 liter - Part No. 5 701 042 605,  
can 1.0 liter - Part No. 5 701 042 610).  
Caution: Do not oil up contacts.
3. The self-lubricating bushing pressed into the bearing end plate is permanently lubricated. Therefore, do not clean the bearing end plate with gasoline or similar.

1 = Bearing end plate

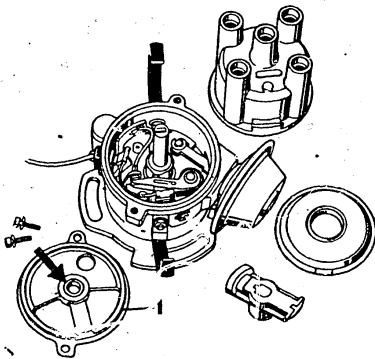

**BOSCH**

Vertriebsabteilung KH, Kundendienst, Kfz-Abteilung  
© by Robert Bosch GmbH, D-7 Stuttgart 1, Postfach 50. Printed in the Federal Republic of Germany.  
Imprimé en République Fédérale d'Allemagne par Robert Bosch GmbH.

**L1**

Technical Bulletin

Ignition distributor 0 231 ...



# After-sales Service

## Service Information

Observe  
the new workshop  
filing system!

Only for use within the Bosch organization. Not to be communicated to any third party.

23

VDT-I-230/102 B

Ed. 1

Translation of German  
edition of 28.8.1975

### Maintenance of Contact Points in Ignition Distributor

Ignition system troubles are frequently caused by a lack of maintenance at the distributor contact points, viz:

#### 1. Wrong contact gap/dwell angle

Installing replacement contact points without greasing the rubbing block leads to a high degree of wear, with the result that the contact gap becomes too small after a short period of service.

#### Remedy:

Grease the rubbing block as prescribed (VDT-WJE 120/1 B) with Ft 1 v 4 special grease.

Part Number of	50 g	tube	5 700 002 005		
"	"	"	250 g	tube	5 700 002 025

Some types have a built-in lubricating sponge or piece of felt as standard, for cam lubrication. These should be checked visually.

Replace distributors whose cams have damaged surfaces.

After installing replacement contact points, set the dwell angle to the lower tolerance limit.

#### 2. Dirt fouling

Do not overlubricate ignition distributors, but keep the contact surfaces clean and grease-free. The protective cap for the contact points built-in as standard in some types must be replaced after charging the points.

Brown-blackish contact surfaces indicate lubricant deposits.

#### 3. Breaker-triggered semiconductor ignition systems

Points 1 and 2 are of particular importance here. Too small a contact gap encourages the possible formation of tungsten oxide due to the condenser discharge when the points close, which leads to increased contact resistance and a recognisable blue discoloration of the contact points. Contact resistances of 20 ohms or more lead to faults in TCI systems.

**BOSCH**

Geschäftsbereich KH Kundendienst, Kfz-Ausrüstung  
© by Robert Bosch GmbH, D-7 Stuttgart 1, Postfach 50 Printed in the Federal Republic of Germany  
Imprimé en République Fédérale d'Allemagne par Robert Bosch GmbH

L2

Technical Bulletins

Ignition distributor 0 231 ...



The condenser is only for interference suppression purposes on breaker-triggered TCI systems, and can either:

- be removed completely
- be replaced by an interference suppression filter, e.g. 0 290 002 021/022,
- or be replaced by screening cable 1, with one end of ground connection grounded to ignition distributor.

For Daimler-Benz vehicles with 8-cylinder engines, screened control leads have been brought out:

- Part No. 1 234 431 251 for TCI trigger boxes similar to 0 227 051 014 with pin terminal,
- Part No. 1 234 431 252 for TCI trigger boxes similar to 0 227 051 015 with triple blade terminal, or to 0 227 051 017 with individually connectable cable ends.

In case of inquiry, please contact your authorized representative.

ROBERT BOSCH GMBH  
Geschäftsbereich K 1  
Abteilung VAK 6

**L3**

Technical Bulletins

Ignition distributor 0 231 ...



# After-sales Service

## Service Information

Observe  
the new workshop  
filing system!

Only for use within the Bosch organization. Not to be communicated to any third party.

Distributor contact points for Daimler-Benz  
3.5 and 4.5 l engines.

**23**

VDT-I-230/102 B

Suppl. 1 10.1975

Ed. 1

Translation of German  
edition of 1.10.1975

In addition to the screened control leads (TCI), which have already been dealt with a new distributor contact set has been specified for the engines quoted above.

old:	new:	for:
1 237 013 084	.. 142	ZV 0 231 401 .. and 402
1 237 013 110	.. 128	ZV 0 231 403 .. , 0 231 401 004 und 0 231 402 008 0 231 404 002

The new sets contain a grease capsule (not shown) (1 217 402 001) with grease Ft 1 v 4 and a cover 1 230 583 004. The rubbing block is of extra-hard-wearing polyimide.

Lubrication as usual (see Fig.).



The new cover must be fitted.

The contact sets for the 6-cyl. and 4-cyl. engines have not changed, and the original types will continue to be fitted. Care must be taken to route the wiring correctly.

In case of inquiry, please contact your authorized representative.

Published by:  
Trade Division K 1  
Dept. K 1/VAK 6

**BOSCH**

Geschäftsbereich KH, Kundendienst, Kfz-Ausstattung  
© by Robert Bosch GmbH D-7 Stuttgart 1, Postfach 50 Printed in the Federal Republic of Germany  
Imprimé en République Fédérale d'Allemagne par Robert Bosch GmbH

**L4**

Technical Bulletins

Ignition distributor 0 231 ...

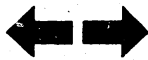

# After-sales Service

## Technical Bulletin

Only for use within the Bosch organization. Not to be communicated to any third party.

Removal of the Ignition Condenser

**23**  
VDT-I-230/102 B

Suppl. 2  
7. 1976

In our technical bulletin VDT-I-230/102 B Ed. 1 together with the supplement of 10.75 we dealt specially with the maintenance of distributor contact points. At the same time the practicability of removing the ignition condenser was described in conjunction with the TCl ignition system (breaker-triggered).

To prevent any misunderstandings we would like to point out as a precaution, that this recommendation can not, of course, be applied to conventional ignition systems, due to the high switching currents involved.

Here, as before, the condenser on the ignition distributor is absolutely essential for spark suppression. A missing or faulty (open-circuit) ignition condenser leads to heavy contact arcing with extreme contact wear, bad ignition performance and finally to complete failure of the ignition system.

The testing procedure for ignition condensers is contained in VDT-WPE 120/2 B. In doubtful cases we recommend the replacement of the ignition condenser.

**BOSCH**

Geschäftsbereich Kfz-Kundendienst, Kfz-Ausstattung  
© by Robert Bosch GmbH, D-7 Stuttgart 1, Postfach 50 Printed in the Federal Republic of Germany.  
Imprimé en République Fédérale d'Allemagne par Robert Bosch GmbH.

**L5**

Technical Bulletin  
Ignition distributor 0 231 ...



# After-sales Service

## Technical Bulletin

Only for use within the Bosch organization. Not to be communicated to any third party.

23

VDT-1-230/103

0 231.. Distributor rotor for Ford V 6 models

Ed. 1

22.9.1975

The corrective action described in VDT-BME 121/86 is not sufficient in every case. If, despite using distributor rotor 1 234 332 173 or ..197 made of polyester with long spring, it still rises up on the cam, it is possible to use a special version made of Bakelite.

This special rotor can be obtained from K 1/VLP at a K-price of 6.--DM less discount under the non-released Part Number D 231 007 360 with DB 11 order.

Rotors of the various versions which have been the subject of complaint should be sent in - irrespective of the warranty period - together with the filled-in warranty plain text voucher/punched card, accompanied by an explanatory note stating the total mileage of the engine, to

ROBERT BOSCH GMBH  
KH/LAV  
zur Weiterleitung an K1/VAK 6  
Postfach 30 02 20  
7000 Stuttgart 30

In the warranty report always enter as the replaced part only a distributor rotor 1 234 332 197. The work can be carried out free of charge as goodwill for the customer. We will reimburse you with the net price of a distributor rotor 1 234 332 197 and 2 work units.

Published by:  
Division K 1  
Dept. K1/VAK 6

**BOSCH**

Geschäftsbereich KH Kundendienst, Kiz-Ausrichtung  
© by Robert Bosch GmbH, D-7 Stuttgart 1, Postfach 50. Printed in the Federal Republic of Germany.  
Imprimé en République Fédérale d'Allemagne par Robert Bosch GmbH.

L6

Technical Bulletins

Ignition distributor 0 231 ...



# After-sales Service

## Technical Bulletin

Only for use within the Bosch organization. Not to be communicated to any third party.

IGNITION SAFEGUARD WITH IGNITION  
DISTRIBUTORS 0 231 178 016  
.. 017

VDT-1-231/102 En  
4.1980

VOLVO - PENTA Marine engines

### RISK OF ACCIDENT

#### General

The US Coast Guard Regulations for gasoline-driven boat engines demand a so-called "ignition safeguard" in the products for the electrical engine equipment (including the ignition distributor). This is to make sure that explosions do not occur when operated in a combustible atmosphere.

#### "Ignition safeguard" characteristics

The following special precautions have been introduced in ignition distributors with "ignition safeguard":

bolter distributor cap without ventilation slots, but with 2 plugs with labyrinth ventilation in the upper part of the housing;

round primary cable lead-through instead of rectangular;

perforated plate and metal strainer ring in the lower part of the housing for sealing the housing ventilation holes (recognizable from below through the ventilation bores).

Up to FD 932 the distributor housing has a recess for an O-ring. From FD 041 the O-ring between the distributor housing and the distributor cap is dispensed with and with it the recess in the distributor housing.

#### Workshop instructions

During all repair work on ignition distributors with a recess for an O-ring in the distributor housing, care should be taken to see that a missing or damaged O-ring is replaced.

When repairs are carried out you should check to see that the special precautions described in the section "Ignition safeguard characteristics" are fitted. There should be no additional holes or openings in the ignition-distributor housing or in the distributor cap.

**BOSCH**

Geschäftsbereich KH, Kundendienst, Kfz-Ausrüstung  
© by Robert Bosch GmbH, D-7 Stuttgart 1, Postfach 50 Printed in the Federal Republic of Germany.  
Imprimé en République Fédérale d'Allemagne par Robert Bosch GmbH

L7

Technical Bulletins

Ignition distributor 0 231 ...





# After-sales Service

## Technical Bulletin

Only for use within the Bosch organization. Not to be communicated to any third party.

IGNITION-DISTRIBUTOR ROTOR

VDT-I-231/104 En

with speed limitation

4.1981

023 ..

Cross-reference of distributor rotors with and without speed limitation and with details of cutoff speed.

Instructions relating to the certificate of registration in the Federal Republic of Germany (In other countries the relevant regulations should be observed).

The fitting of a distributor rotor with limitation is permitted, when the output and rated engine speed of the vehicles are not thereby affected (see certificate of registration, column A, paragraph 7). The cutoff speed must not be lower than the rated engine speed.

When a distributor rotor without limitation is fitted in vehicles which have as original equipment a distributor rotor with limitation, or in the certificate of registration of which a distributor rotor with limitation is entered, the general homologation (ABE) is no longer valid.

Distributor rotor without speed limitation	Distributor rotor with speed limitation	Cutoff speed min <sup>-1</sup>
1 234 332 173	1 234 332 284	5.900
1 234 332 173	1 234 332 317	6.100
1 234 332 173	1 234 332 272	6.200
1 234 332 173	1 234 332 225	6.300
1 234 332 173	1 234 332 196	6.600
1 234 332 173	1 234 332 223	7.000
1 234 332 177	1 234 332 217	5.300
1 234 332 177	1 234 332 203	5.850
1 234 332 177	1 234 332 238	6.300
1 234 332 177	1 234 332 202	6.500
1 234 332 215	1 234 332 218	3.600
1 234 332 215	1 234 332 192	4.500
1 234 332 215	1 234 332 209	5.300
1 234 332 215	1 234 332 144	5.400
1 234 332 215	1 234 332 207	5.800
1 234 332 215	1 234 332 222	6.000

**BOSCH**

Geschäftsbereich KH, Kundendienst, Kfz-Ausübung  
© by Robert Bosch GmbH, D-7 Stuttgart 1, Postfach 50 Printed in the Federal Republic of Germany  
Imprimé en République Fédérale d'Allemagne par Robert Bosch GmbH

**L8**

Technical Bulletins

Ignition distributor 0 231 ...



Distributor rotor without speed limitation	Distributor rotor with speed limitation	Cutoff speed min <sup>-1</sup>
1 234 332 215	1 234 332 220	6.350
1 234 332 215	1 234 332 288	6.400
1 234 332 215	1 234 332 198	6.500
1 234 332 215	1 234 332 208	6.600
1 234 332 215	1 234 332 242	6.700
1 234 332 215	1 234 332 199	6.800
1 234 332 215	1 234 332 224	6.900
1 234 332 215	1 234 332 221	7.000
1 234 332 215	1 234 332 205	7.100
1 234 332 215	1 234 332 206	7.300
1 234 332 271	1 234 332 297	6.600
1 234 332 271	1 234 332 299	6.700
1 234 332 271	1 234 332 274	6.900



## Table of Contents

<u>Section</u>	<u>Coordinate</u>
Structure of microfiche	A 1
1. Test specifications	A 2
2. Necessary test equipment, tools	A 3
3. Lubricants, lubrication table	A 4
4. Testing	B 1
4.1 Test information	B 1
4.2 Visual examination	B 2
4.3 Testing the dwell angle	B 3
4.4 Testing the contact gap	B 5
4.5 Testing the ignition condenser	B 5
4.6 Testing the centrifugal advance	B 6
4.7 Testing the vacuum advance	B 11
4.7.1 Testing the vacuum unit for leaks	B 11
4.7.2 Testing the vacuum advance	B 14
4.8 Testing the vacuum/overpressure advance - pressure unit with one or two connecting pipes	B 18
4.8.1 Testing the vacuum unit or overpressure unit for leaks	B 18
4.8.2 Testing the vacuum advance	B 20
4.8.3 Testing the overpressure advance	C 1
5. Testing the engine-speed limiter	C 8
Technical Bulletins	L 1

**L24**

Table of contents

Ignition distributor 0 231 ...

